

# Cortacésped FANTON mod. "FRA46Q"

**FIG.1 CRANKCASE. / GEAR ASSY, GOVERNOR.**

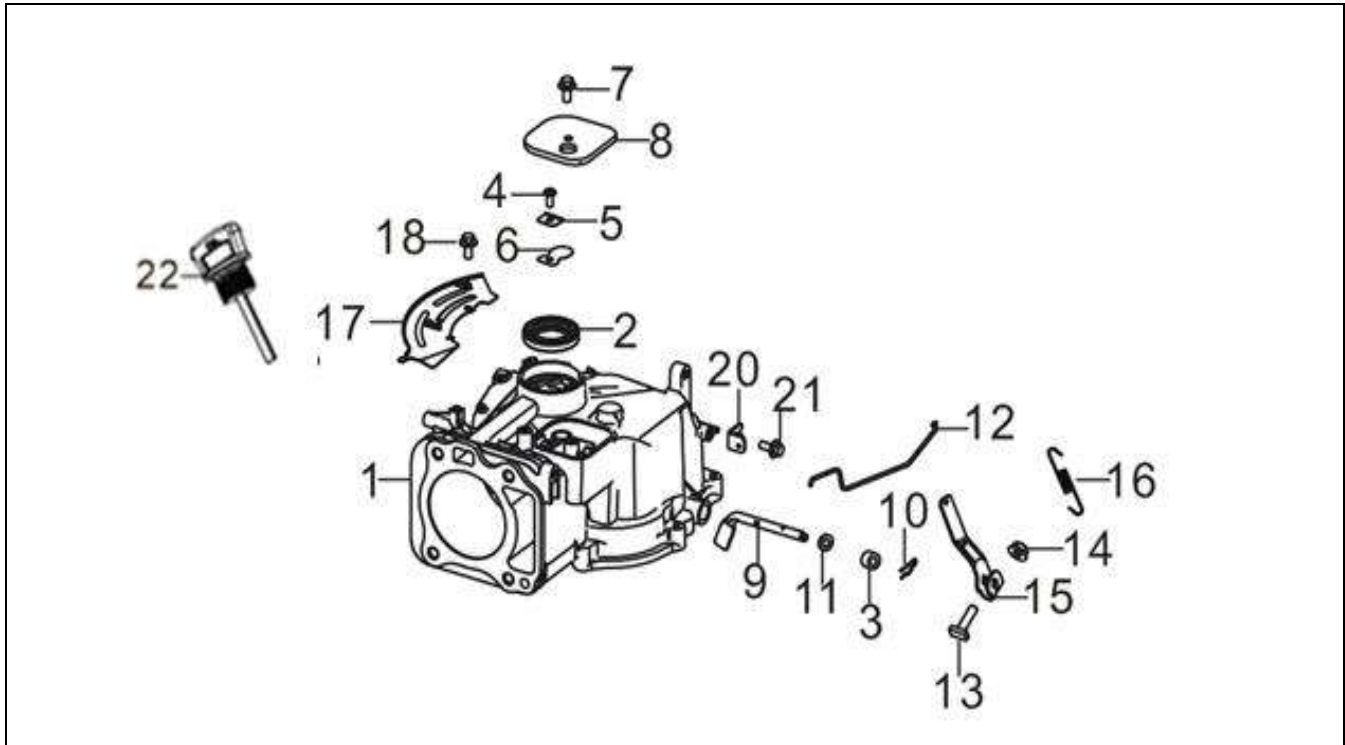

REF.NO.	PART NO	DESCRIPTION	Q'TY
E01-1	11310-Z2P0112-00A1		1
E01-2	90682-Z240110-00A0		1
E01-3	90682-Z030210-00A0		1
E01-4	90103-0410-51A0		1
E01-5	11321-Z2P0110-00A0		1
E01-6	11337-Z2P0110-00A0		1
E01-7	90007-0512-A1A0		1
E01-8	11333-Z2P0110-00A0		1
E01-9	16061-Z2P0110-00A0		1
E01-10	90501-Z010110-00A0		1
E01-11	90412-Z870210-00A0		1
E01-12	16062-Z2P0110-00A0		1
E01-13	16072-Z010110-00A0		1
E01-14	90305-0600-31A0		1
E01-15	16070-Z2P0110-00A1		1

E01-16	16063-Z2P0110-00A0		1
E01-17	19308-Z2P0110-00A0		1
E01-18	90007-0512-A1A0		1
E01-20	16561-Z2P0110-00A0		1
E01-21	90007-0512-A1A0		1
E01-22	15010-Z2P0110-Q5A0		1

## FIG.2 COVER SUBASSEMBLY, CRANKCASE

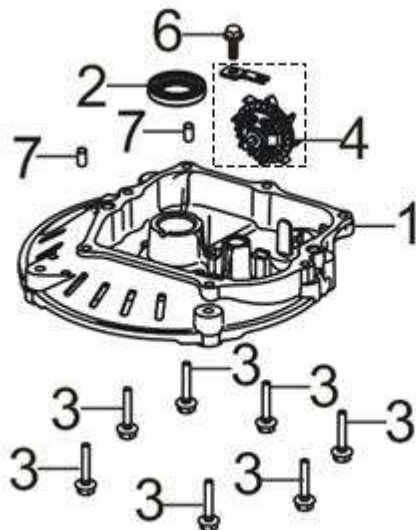

REF.NO.	PART NO	DESCRIPTION	Q'TY
E02-1	11411-Z2P0112-00A0		1
E02-2	90682-Z030320-00A0		1
E02-3	90001-0630-01A0		7
E02-4	16400-Z2P0111-00A0		1
E02-6	90001-0614-01A0		1
E02-7	90502-0812-00A0		2

**FIG.3 HEAD SUBASSEMBLY, CYLINDER / PLUG,SPARK**

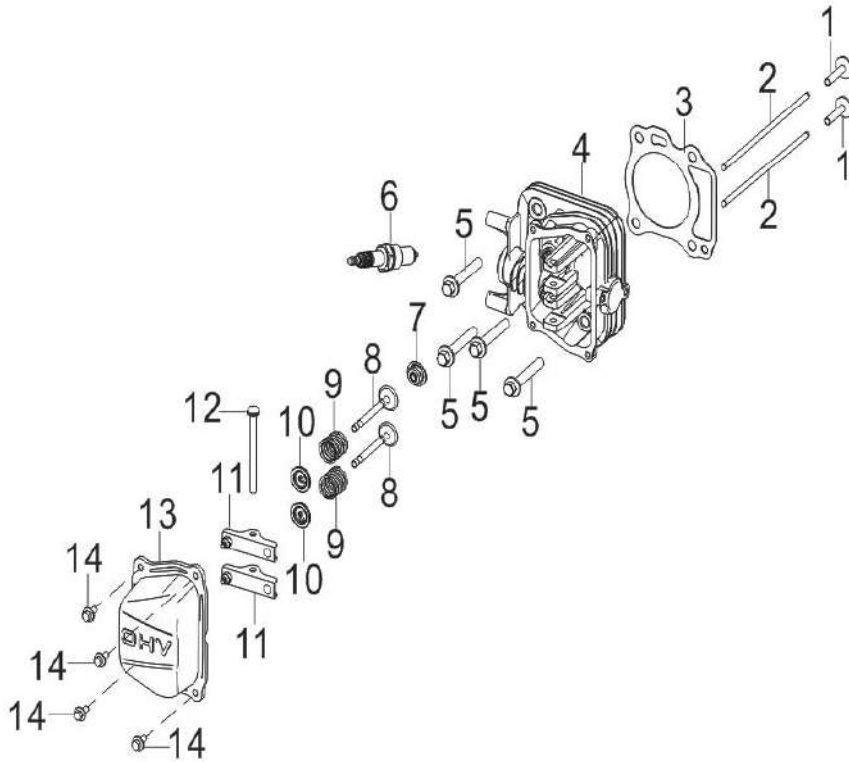

REF.NO.	PART NO	DESCRIPTION	Q'TY
E03-1	14081-Z2P0110-00A0		2
E03-2	14071-Z2P0110-00A0		2
E03-3	12131-Z2P0110-00A0		1
E03-4	12140-Z2P0111-00A0		1
E03-5	90001-0850-01A0		4
E03-6	30010-Z120110-00A1		1
E03-7	12101-Z010110-00A0		1
E03-8	12110-Z2P0110-00A0		2
E03-9	12103-Z030110-00A0		2
E03-10	12112-Z010110-00A0		2
E03-11	14310-Z2P0110-00A0		2
E03-12	14330-Z2P0110-00A0		1
E03-13	12411-Z2P0110-00A0		1
E03-14	90007-0512-A1A0		4

# FIG.4 ROD,CRANKSHAFT CONNETING

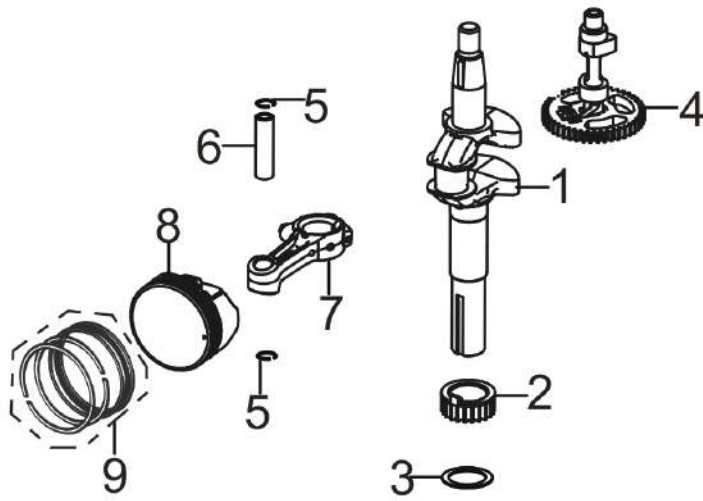

REF.NO.	PART NO	DESCRIPTION	Q'TY
E04-1	13300-Z2P0910-00A0		1
E04-2	14014-Z2P0211-00A0		1
E04-3	90408-Z030210-00A0		1
E04-4	14200-Z2P0112-00A0		1
E04-5	13122-Z240110-00A0		2
E04-6	13121-Z240110-00A0		1
E04-7	13010-Z2P0110-00A0		1
E04-8	13111-Z2P0111-00A0		1
E04-9	13200-Z180120-00A0		1

## FIG.5 STARTER,RECOIL

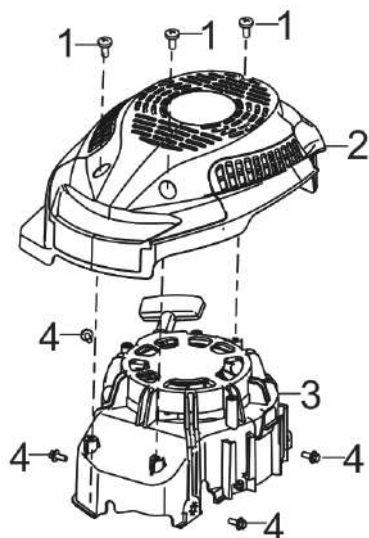

REF.NO.	PART NO	DESCRIPTION	Q'TY
E05-1	90124-Z2P0210-01A0		3
E05-2	80001-Z2P0111-JCA0		1
E05-3	28200-Z2P0311-Q2A0		1
E05-4	90007-0520-A1A0		4

**FIG.6 CARBURETOR ASSY.**

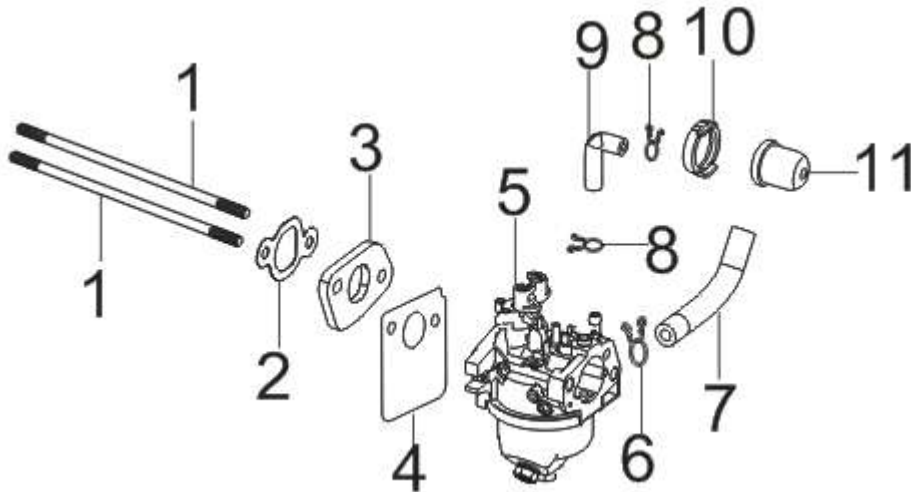

REF.NO.	PART NO	DESCRIPTION	Q'TY
E06-1	90204-Z010210-01A0		2
E06-2	17002-Z2P0110-00A0		1
E06-3	16003-Z2P0110-00A0		1
E06-4	16004-Z2P0110-00A0		1
E06-5	16100-Z2P0210-00M1		1
E06-6	90685-1000-01A0		1
E06-7	90686-Z2P0210-00A0		1
E06-8	90685-0700-01A0		2
E06-9	16211-Z2P0110-00A0		1
E06-10	16212-Z2P0110-00A0		1
E06-11	16213-Z2P0110-00A0		1

# FIG.7 FLYWHEEL / IMPELLER / STARTER PULLEY / IGNITION COIL

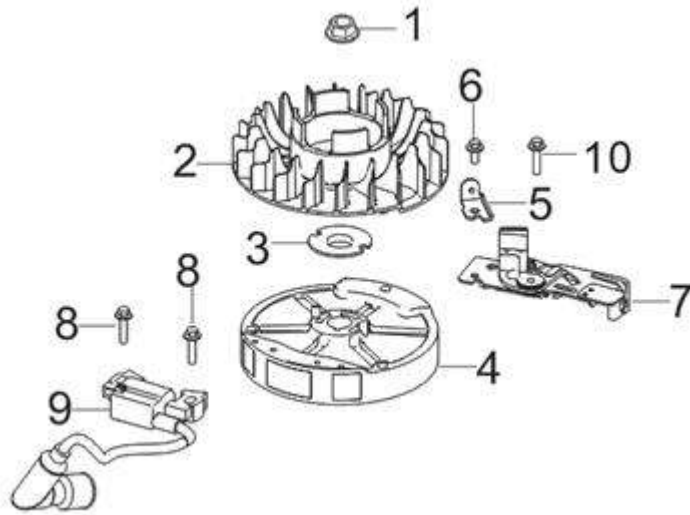

REF.NO.	PART NO	DESCRIPTION	Q'TY
E10-1	13501-Z010110-00A0		1
E10-2	19352-Z2P0410-00A0		1
E10-3	28020-Z2P0110-00A0		1
E10-4	13510-Z2P0111-00A0		1
E10-5	30029-Z2P0110-00A0		1
E10-6	90007-0514-A1A0		1
E10-7	45200-Z2P0411-00A1		1
E10-8	90007-0525-A1A0		2
E10-9	30400-Z2P0110-00A0		1
E10-10	90007-0520-A1A0		1



# FIG.8 CLEANER, AIR )

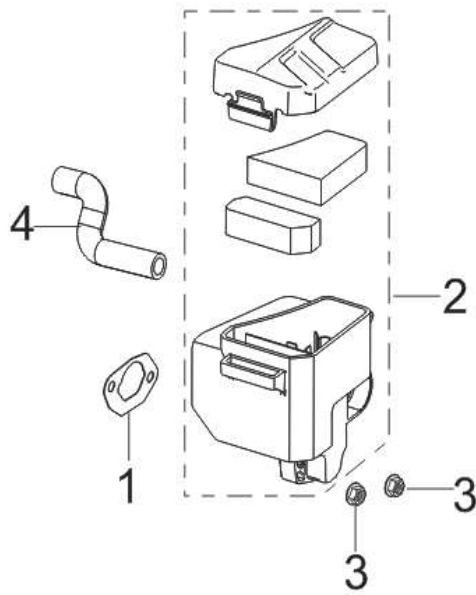

REF.NO.	PART NO	DESCRIPTION	Q'TY
F01-1	17001-Z2P0110-00A0	#;REF!	1
F01-2	17100-Z2P0111-00A0	#;REF!	1
F01-3	90305-0600-31A0	#;REF!	2
F01-4	17004-Z2P0110-00A0	#;REF!	1

# FIG.13 MUFFLER ASSY.

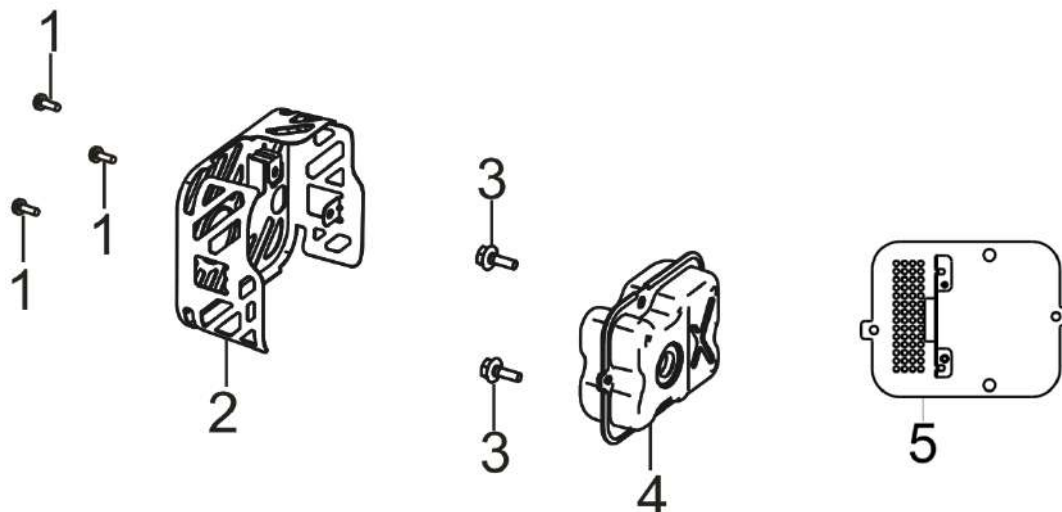

REF.NO.	PART NO	DESCRIPTION	Q'TY
F02-1	90124-Z2P0110-01A0	#N/A	3
F02-2	18130-Z2P0110-00A0	#N/A	1
F02-3	90001-0616-01A0	#N/A	2
F02-4	18100-Z2P0110-00A0	#N/A	1
F02-5	18020-Z2P0112-00A0	#N/A	1

# FIG.14 TANK ASSY, FUEL

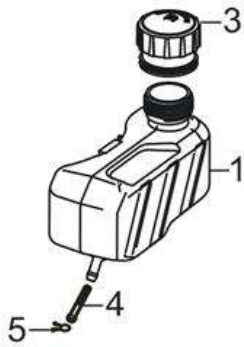

REF.NO.	PART NO	DESCRIPTION	Q'TY
F03-1	16600-Z2P0110-Q2N0	#N/A	1
F03-3	16730-Z250210-00A0	#N/A	1
F03-4	16652-Z030110-00A0	#N/A	1
F03-5	90685-1000-01A0	#N/A	1

**FIG.15 (F04) CORTACESPED**

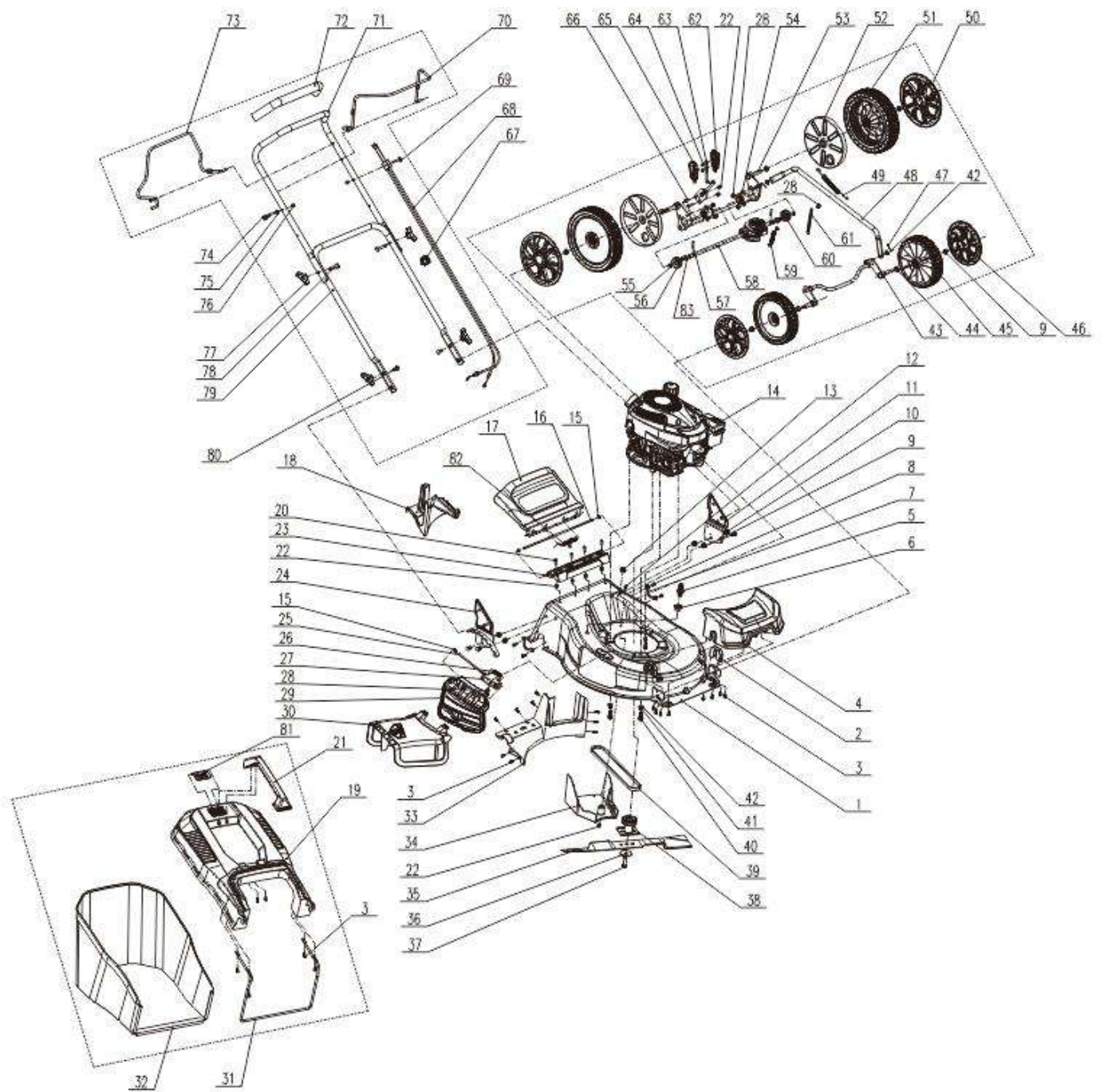

REF.NO.	PART NO	DESCRIPTION	Q'TY
F04-1	75001-G070110-H7A0		1
F04-2	44033-G030110-Q2A0		2
F04-3	90120-5014-03		23
F04-4	79243-G030110-Q2A0		1
F04-5	79277-G080110-Q2A0		1
F04-6	13501-Z010110-00A0	NUT, FLYWHEEL	1
F04-7	42005-G030110-00A0		2
F04-8	90027-0612-56		4
F04-9	90308-0800-31A0	TYPE 2 NON-METALLIC INSERT HEXAGON LOCK NUT WITH FLANGE	8
F04-10	90028-0816-01		4
F04-11	79236HG030110-H7A0		1
F04-12	90028-0616-01		1
F04-13	90737-G030110-Q2A0		1
F04-15	90575-0500-0601	SPLIT WASHER	4
F04-16	79259-G030110-00A0		1
F04-17	79257-G030110-RTA0		1
F04-18	79211-G070110-00A0		1
F04-19	79252-G030110-Q2A0		1
F04-20	90103-0612-5101	CROSS-RECESSED PAN HEAD SCREW	4
F04-21	79253-G030110-Q2A0		1
F04-22	90308-0600-31	TYPE 2 NON-METALLIC INSERT HEXAGON LOCK NUT WITH FLANGE	7
F04-23	79244-G030110-Q2A0		1
F04-24	79237HG110110-H7A0		1

F04-25	79249-G030110-00A0		1
F04-26	79250-G030110-00A0		1
F04-27	79248-G030110-00A0		1
F04-28	90001-0610-0101	HEXAGON SOCKET FLANGE FACE BOLT - SMALL SERIES	6
F04-29	79241HG030110-RTA0		1
F04-30	79240-G030110-Q2A0		1
F04-31	79255-G030110-H6A0		1
F04-32	79256-G030210-00A2		
F04-33	79239-G030110-Q2A0		1
F04-34	79265-G070110-00A0		1
F04-35	73101-G070110-00A0	BLADE	1
F04-36	90419-G030110-0000	DISC WASHER	1
F04-37	90007-Z2P0310-00A0	HEXAGON SOCKET FLANGE FACE BOLT - BIG SERIES - GRADE B	1
F04-38	73002-G080110-00A0		1
F04-39	90566-1070-0001		1
F04-40	90039-0825-0101		3
F04-41	90403-0800-Z108		3
F04-42	90408-0800-E108	FLAT WASHER - GRADE A	2
F04-43	44020HG110110-0000	SHAFT, FRONT WHEEL	1
F04-44	90405-G130110-0000	WAVE ELASTIC WASHER	4
F04-45	40206-G060110-00A0		2
F04-46	40207-G030210-JCA0		2
F04-47	90501-0220-0108	COTTER PIN	2
F04-48	79262-G110110-RTA0		1
F04-49	79263-G030110-00A0		1

F04-50	40207-G060110-JCA0		2
F04-51	40205-G060110-00A0		2
F04-52	40204-G060110-00A0		2
F04-53	42002HG110110-0000	SHAFT, REAR WHEEL	1
F04-54	51179-G060110-00A0	SHAFT SLEEVE	2
F04-55	90573-1200-06	CIRCLIP FOR SHAFT - TYPE A	4
F04-56	40202-G030210-00A0		1
F04-57	40203-G030110-00A0		2
F04-58	24300-G110110-00A0	RETARDER PART	1
F04-59	79266-G030110-00A0		1
F04-60	40202-G030110-00A0		1
F04-61	90684-Z030120-00A0	WIRE CLIP	1
F04-62	79261-G030210-RTA0		1
F04-63	79275HG020110-00A0		1
F04-64	90107-4295-01A0	CROSS-RECESSED PAN HEAD SELF-TAPPING SCREW	2
F04-65	79261-G030110-RTA0		1
F04-66	90005-0616-01A0	HEXAGONAL HEAD BOLT - FULL THREAD	2
F04-67	90684-U070111-0000	WIRE CLIP	1
F04-68	79230-G080110-00A0		1
F04-69	90211-G080110-00A0		1
F04-70	79224-G080110-RTA0		1
F04-71	79223-G080110-H7A0		1
F04-72	54101-G030110-Q200	SLEEVE, HANDLE RUBBER	1
F04-73	79225-G080110-H7A0		1

F04-74	79278-G080110-00A0		1
F04-75	90305-0600-3108	HEXAGON NUT WITH FLANGE	1
F04-76	90314-0600-31	ACORN HEXAGON NUTS	2
F04-77	79226-G080110-RTA0		4
F04-78	90031-G080110-0000		2
F04-79	79231-G130110-H7A0		1
F04-80	90029-G080210-00A0		2
F04-81	79254-G030110-Q2A0		1
F04-82	79258-G030110-00A0		1
F04-83	90412-YBW0210-01A0	FLAT WASHER	2